

Construction

The GEMÜ 1435 ePos® digital electro-pneumatic positioner detects the valve position via its external LongLife travel sensor. It has a solid housing with protected operating buttons and an easy to read LC display. The operating times can be set by integrated throttles. Connection and mounting to NAMUR is also possible.

Features

- Simple, self-explanatory menu
- Automatic initialisation function
- Fail safe function in case of compressed air and power supply failure
- Protection class IP 65
- 3/4-wire type
- Can be used for linear and quarter turn actuators
- Operation with single and double acting actuators

Advantages

- Remote mounting of positioner and travel sensor is possible
- Simple handling and commissioning
- Simple electrical connection by detachable terminals
- Automatically optimises the valve control during initialisation
- No air consumption when idle



Front view GEMÜ 1435 ePos®

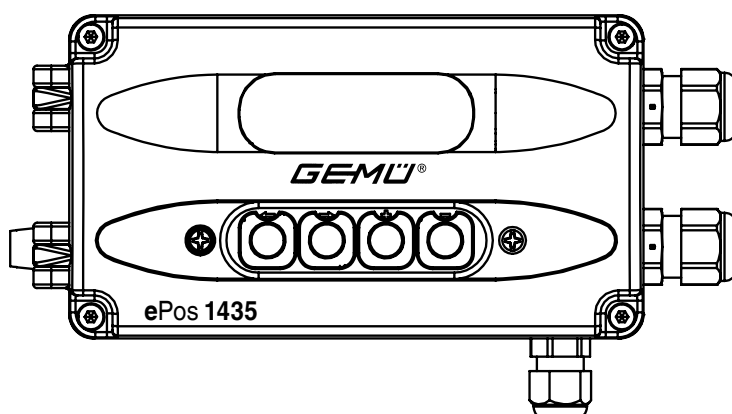

Technical data

General information

Protection class to EN 60529	IP 65
Dimensions L x W x H	160 x 90 x 84 mm
Weight	1.6 kg
Mounting position	Optional
Directives	
EC low voltage	2006/95/EG
EMV directive	2004/108/EG
Conformities	
Interference resistance	DIN 61000-6-2 (March 2006) DIN 61326-1 (industry)
Interference emission	DIN 61000-6-3 DIN 61326-1 (industry)
Particulars - Fail safe function in case of compressed air and power supply failure (see table on page 11) - For control function 2 (NO function) please order throttle 1435DR_Z.	

Electrical data

Digital outputs	
Switching outputs	Alarm output 1, Alarm output 2, Error message output
Type of contact	PNP
Pull-down resistance	120 k Ω
Switching voltage	Power supply
On-load current	max. 0.5A
Short-circuit proof	yes
Electrical connections	
Standard	
Power supply	M16 cable entry
Input signal	M16 cable entry
Travel sensor	M12 cable entry
Recommended diameter of connection cable	5 - 10 mm
Terminals	Wago 236
Cross section of wire	0.5...2.5 mm ² AWG 20...12
Optional	
Power supply, alarm outputs	M12 plug, 5-pin
Input / output signals	M12 plug, 5-pin
Travel sensor	M12 socket, 5-pin

Electrical data

Power supply	
Power supply	24 V DC -5/+10 %
Power consumption	\leq 4.2 W (when idle)
Standard	\leq 6,5 W (Control operation, single acting 50 l/min) \leq 9,8 W (Control operation, double/single acting 90 l/min)
Optional with heating element	\leq 25 W
Duty cycle	continuous duty
Reverse battery protection	yes
Characteristic accuracy	\leq 1 %
Analogue input 0/4-20 mA	
Set value	0/4-20 mA
Accuracy / Linearity	\leq \pm 0.3 % of full flow
Input type	passive
Input resistance	50 Ω
Resolution	12 bit
Reverse battery protection	yes
Analogue input 0-10 V	
Set value	0-10 V
Accuracy / Linearity	\leq \pm 0.3 % of full flow
Input type	passive
Input resistance	100 Ω
Resolution	12 bit
Reverse battery protection	yes
Analogue output 0-10 V	
Actual value output	0-10 V
Accuracy	\leq \pm 1 % of full flow
Output type	active
On-load current	max. 10 mA
Resolution	12 bit
Short-circuit proof	yes
Analogue output 0/4-20 mA (optional)	
Actual value output	0/4-20 mA
Accuracy	\leq \pm 1 % of full flow
Output type	active
Load resistor	max. 600 Ω
Resolution	12 bit
Short-circuit proof	yes

Travel sensor

Linear design	
Mounting	Remote
Stroke	0-30 / 0-50 / 0-75 mm
Permissible minimum stroke	3.0 / 5.0 / 7.5 mm
Resistance R	3.0 / 5.0 / 5.0 k Ω
Connection	Pre-fitted cable (max. 20 m)
Quarter turn design	
Mounting	Remote
Angle of rotation	0-93°
Resistance R	3 k Ω
Connection	Pre-fitted cable (max. 20 m)

Main functions

Control function	· Normally closed · Normally open · Double acting
- Automatic initialisation of actuator and positioner	
- Position standardization Min. Position	
- Position standardization Max. Position	
- Close tight function at min/max positions	
- Linearization function for set value -> Position (linear, 1:25, 1:50, freely programmable)	
- Definition of programmable characteristic curve via 11 points	
For details see parameter table of operating instructions	

Option with heating element

Temperature	\leq 5 °C	Heating active
	\geq 15 °C	Heating inactive

Technical data

Operating conditions	
Ambient temperature	0 to 60 °C -20 to 60 °C with heating element
Storage temperature	0 to 60 °C
Control medium*	Quality classes to DIN ISO 8573-1
Dust content	Class 3 (max. particle size 5 µm) (max. particle density 5 mg/m ³)
Pressure dew point	Class 4 (max. pressure dew point 3 °C)
Oil concentration	Class 3 (max. oil concentration 1 mg/m ³)
Air supply	0 - 6 bar
Air output	50, 90 NI/min, depending on type (P _Z = 6 bar)
Air consumption (when idle)	0 NI/min

Materials	
Housing	Aluminium, epoxy coated
Display cover	PMMA
Keypad cover	PMMA
Travel sensor	Anod. alu } Linear design PEEK } PAI } Quarter turn design NBR }

Note
Filter strainers are installed in the pneumatic connectors of the positioner to protect against rough dirt particles. They can be ordered as spare parts with order number 1435 SFI. Each kit contains 3 filter strainers. These filter strainers are meant as an additional protection and do not replace the requirement to filter all site compressed air.

Order data - Positioner

Field bus	Code
Without	000

Accessory	Code
Accessory	Z

Action	Code
Single acting	1
Double acting	3

Explosion-proof class	Code
Without explosion-proof rating	0

Option	Code
Without	0
Electrical connections M12 5-pin	1*
4-20 mA actual value output	2
4-20 mA actual value output Electrical connections M12 5-pin	3*
4-20 mA actual value output and heating element	4
Electrical connections M12 5-pin and heating element	5*
Heating element	6
4-20 mA actual value output Electrical connections M12 5-pin and heating element	7*

* For versions with M12 connections, suitable cable sockets/plugs are supplied

Version	Code
Electro-pneumatic, 50 l/min	01
Electro-pneumatic, 90 l/min only for action code 1 (single acting)	02

Order example	1435	000	Z	1	0	0	01
Type	1435						
Field bus (code)		000					
Accessory (code)			Z				
Action (code)				1			
Explosion-proof class (code)					0		
Option (code)						0	
Version (code)							01

Required parts for direct mounting

Linear actuators

GEMÜ 1435... (positioner)

GEMÜ 1445 000 Z... (mounting kit)

Quarter turn actuators

GEMÜ 1435... (positioner)

GEMÜ 1445 PTAZ... (mounting kit)

Note: Mounting kit 1445 000 Z... (plastic spindle, spring, threaded adapter if applicable) depends on the valve type. Please order separately specifying valve type, DN and control function.

Mounting kit for direct mounting - Linear actuators

Direct mounting: with mounting bracket

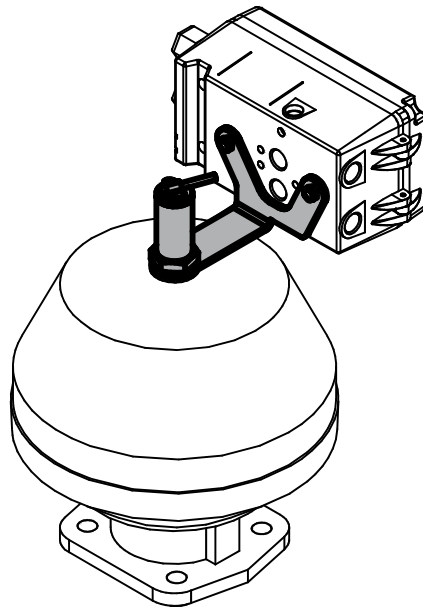

GEMÜ 1445 000 Z 10

Order data - Mounting kit for direct mounting - Linear actuators

Order example	1445	000	Z	10
Type	1445			
Field bus (code)		000		
Accessory (code)			Z	
Mounting kit (code)				10

Note: The mounting kit 1445 000 Z... includes the travel sensor and the mounting parts.

Mounting kits for direct mounting - Quarter turn actuators

GEMÜ 1445 PTAZ ...000...

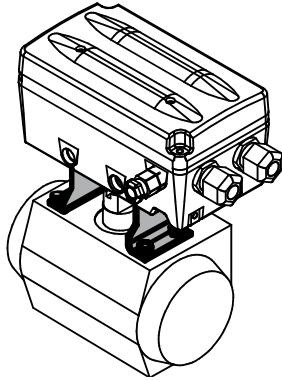

Mounting:
Mounting bracket
Control air connector code 000

GEMÜ 1445 PTAZ ...V...

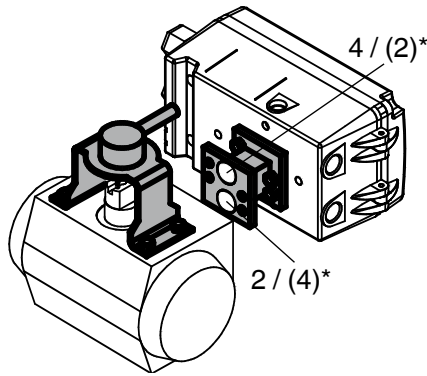

Mounting:
NAMUR adapter V
Control air connector code -V-

GEMÜ 1445 PTAZ ...H...

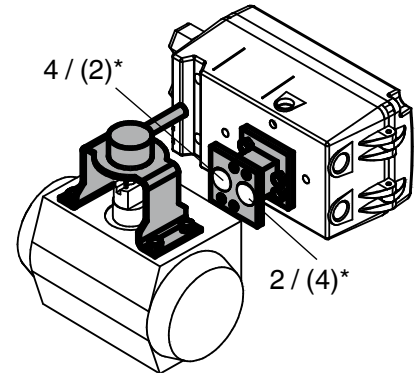

Mounting:
NAMUR adapter H
Control air connector code -H-

Please note the connection of the actuator

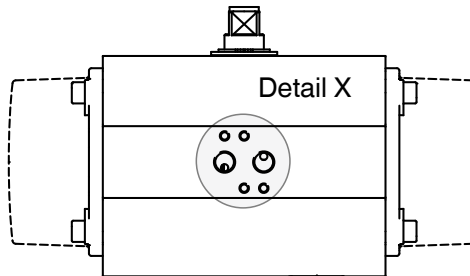

Connection

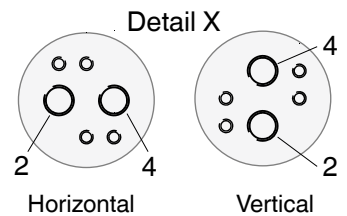

Order data - Mounting kits for direct mounting - Quarter turn actuators

Mounting kit	Code
Mounting kit - quarter turn actuators	PTAZ

NAMUR size	Code
Hole spacing 50x25, shaft height 15	00
Hole spacing 80x30, shaft height 20	01
Hole spacing 80x30, shaft height 30	02
Hole spacing 130x30, shaft height 30	03
Hole spacing 130x30, shaft height 50	04

Measuring range	Code
Angle of rotation 90°	090

Control air connector (NAMUR)	Code
Without	000
Control air connector G 1/8 and G 1/4, Horizontal connection pattern	4HL
Control air connector G 1/8 and G 1/4, Vertical connection pattern	4VB
Control air connector G 1/8 and G 1/4, Vertical connection pattern	4VT*
Control air connector G 1/8 and G 1/4, Horizontal connection pattern	4HR*
Control air connector G 3/8 and G 1/2, Horizontal connection pattern	BHL
Control air connector G 3/8 and G 1/2, Vertical connection pattern	BVB
Control air connector G 3/8 and G 1/2, Vertical connection pattern	BVT*

* Control direction reversed

Order example	1445	PTAZ	00	090	000
Type	1445				
Mounting kit (code)		PTAZ			
NAMUR size (code)			00		
Measuring range (code)				090	
Control air connector (code)					000

Note: The mounting kit 1445 PTAZ... includes the travel sensor and the mounting parts.

Required parts for remote mounting

Linear actuators

GEMÜ 1435... (positioner)
 GEMÜ 4232... (travel sensor)
 GEMÜ 4232 S01 Z... (travel sensor mounting kit)
 GEMÜ 1445 000 Z MP (mounting bracket)

Quarter turn actuators

GEMÜ 1435... (positioner)
 GEMÜ 4231... (travel sensor)
 GEMÜ 4231 PTAZ... (travel sensor mounting kit)
 GEMÜ 1445 000 Z MP (mounting bracket)

Note: Mounting kit 4231 PTAZ.../4232 S01 Z... (threaded adapter if applicable, ...) depends on the valve type. Please order separately specifying valve type, DN and control function.

Mounting kit for remote mounting - Linear actuators

GEMÜ 4232 (travel sensor)
 GEMÜ 4232 S01 (travel sensor mounting kit)

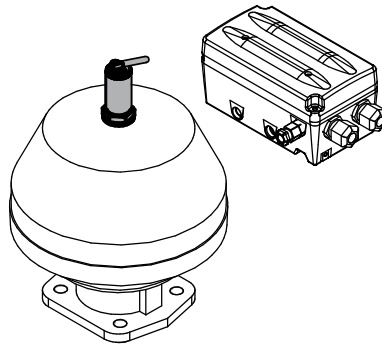

Order data - Travel sensor (linear actuators)

Field bus	Code
Without	000

Accessory	Code
Accessory	Z

Housing material	Code
PP coated	05
Aluminium, black anodized	14
PVDF coated (suitable for High Purity)	20

Travel	Code
Potentiometer, 30 mm length	030
Potentiometer, 50 mm length	050
Potentiometer, 75 mm length	075

Cable length	Code
Length 2.0 m	02M0
Length 5.0 m	05M0
Others on request	

Cable connection	Code
Open wires with multicore cable ends	0000
M12 cable plug, straight, 5-pin, plastic	4001*

* required for positioner version with M12 5-pin electrical connections

Order example	4232	000	Z	14	030	05M0	0000
Type	4232						
Field bus (code)		000					
Accessory (code)			Z				
Housing material (code)				14			
Travel (code)					030		
Cable length (code)						05M0	
Cable connection (code)							0000

Note: Mounting kit 4232 S01 Z... (plastic spindle, spring, threaded adapter if applicable) for travel sensor 4232 depends on the valve type. Please order separately specifying valve type, DN and control function.

Mounting kit for remote mounting - Quarter turn actuators

GEMÜ 4231 (travel sensor)

GEMÜ 4231 PTAZ (travel sensor mounting kit)

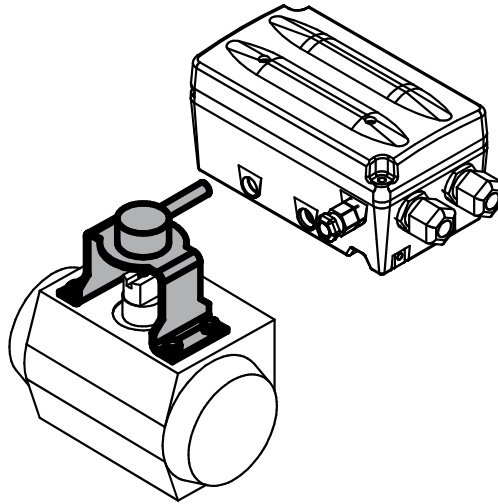

Order data - Travel sensor (quarter turn actuators)

Field bus	Code
Without	000

Accessory	Code
Accessory	Z

Housing material	Code
PAI	XF

Travel	Code
Potentiometer, 90°	090

Cable length	Code
Length 2.0 m	02M0
Length 5.0 m	05M0
Others on request	

Cable connection	Code
Open wires with multicore cable ends	0000
M12 cable plug, straight, 5-pin, plastic	4001*

* required for positioner version with M12 5-pin electrical connections

Order example	4231	000	Z	XF	090	05M0	0000
Type	4231						
Field bus (code)		000					
Accessory (code)			Z				
Housing material (code)				XF			
Travel (code)					090		
Cable length (code)						05M0	
Cable connection (code)							0000

Note: Mounting kit 4231 PTAZ... (distance piece, mounting bracket) depends on the valve type. Please order separately specifying valve type, DN and control function.

Order data - Mounting kit for travel sensor - Quarter turn actuators

Mounting kit	Code
Mounting kit for quarter turn actuators	PTAZ

Measuring range	Code
Angle of rotation 90°	090

NAMUR size	Code
Hole spacing 80x30, shaft height 20	01
Hole spacing 80x30, shaft height 30	02
Hole spacing 130x30, shaft height 30	03
Hole spacing 130x30, shaft height 50	04

Control air connector	Code
Without	000

Order example	4231	PTAZ	01	090	000
Type	4231				
Mounting kit (code)		PTAZ			
NAMUR size (code)			01		
Measuring range (code)				090	
Control air connector (code)					000

Positioner dimensions [mm]

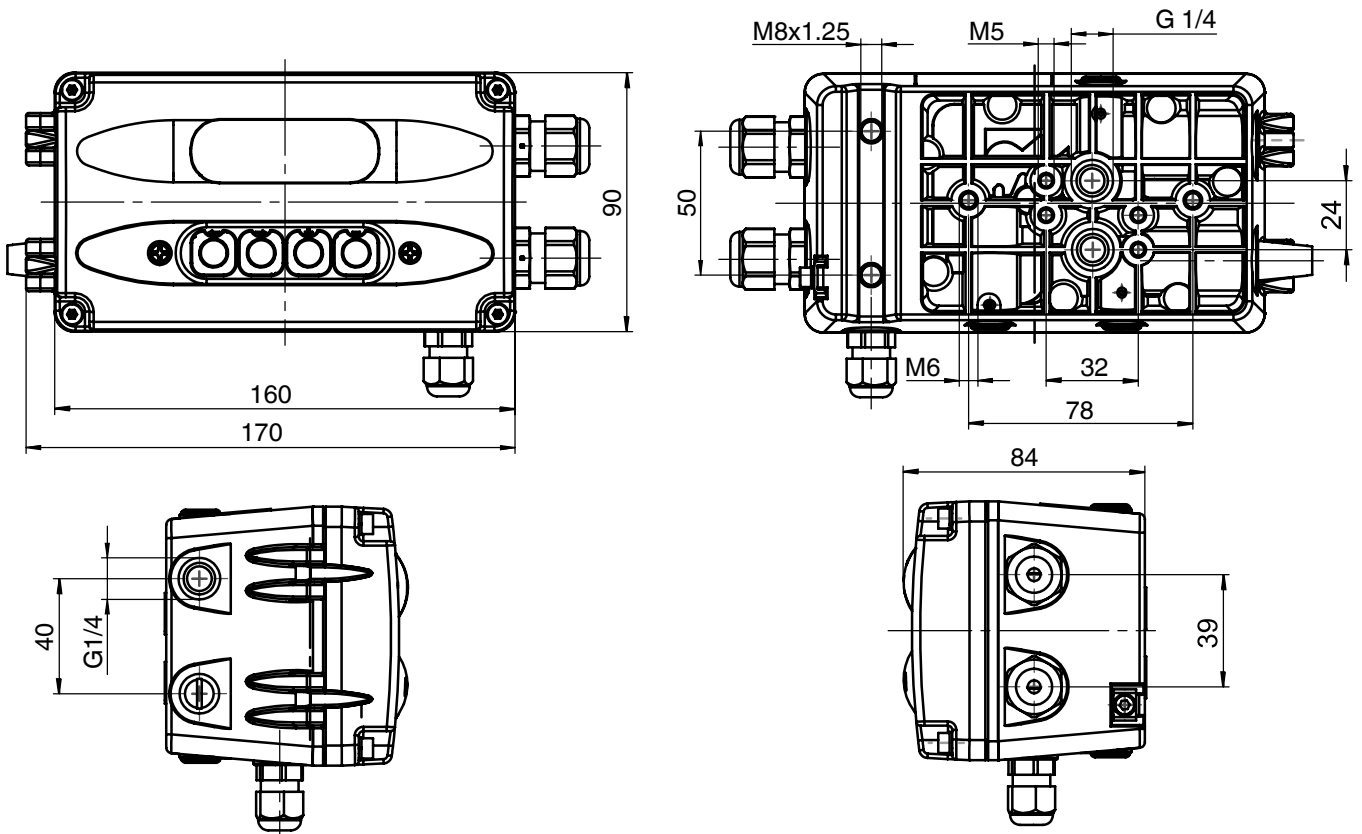

Materials and dimensions - Travel sensor GEMÜ 4232 for linear actuators, remote mounting [mm]

Material version - Aluminium

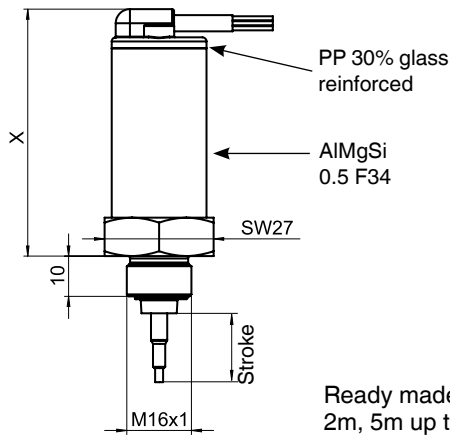

Ready made cable lengths for remote mounting:
2m, 5m up to max. 20m

Travel sensor	
Stroke	X
30	62.2
50	84.2
75	109.2

Material version - PVDF or PP

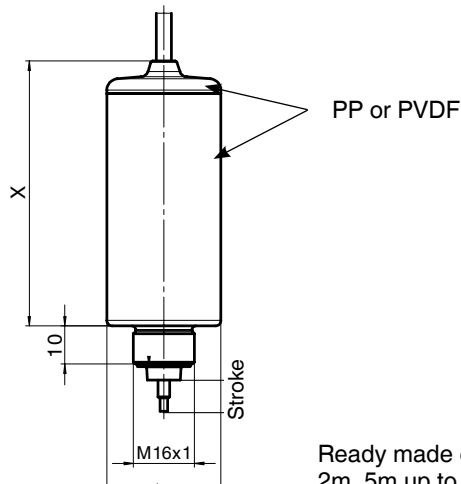

Ready made cable lengths for remote mounting:
2m, 5m up to max. 20m

Travel sensor	
Stroke	X
30	69.6
50	91.6
75	116.6

Materials and dimensions
Rotary travel sensor GEMÜ 4231 incl. bracket, remote mounting [mm]

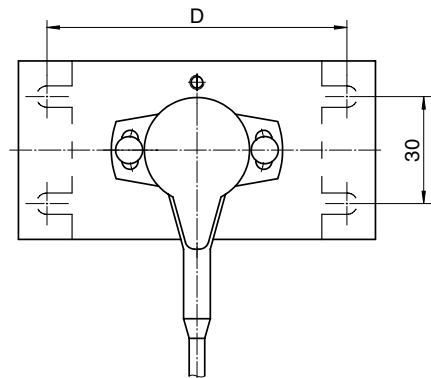
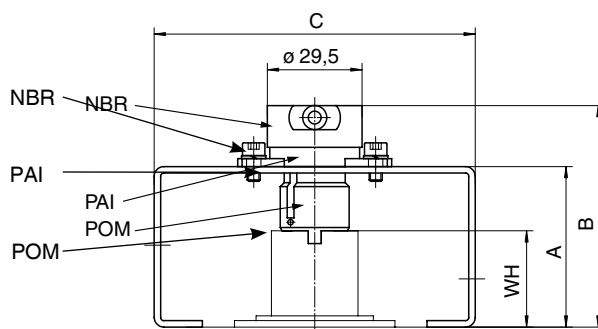

Shaft height WH	Hole spacing D	A	B	C
20	80	40	59	100
30	80	50	69	100
50	130	70	89	150

Dimensions

Mounting bracket GEMÜ 1445 for wall mounting of positioner, remote mounting [mm]

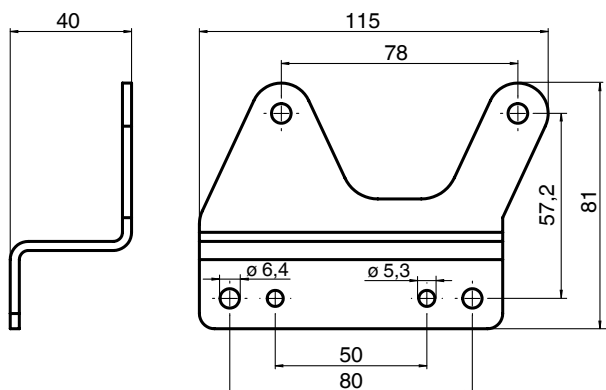

Mounting bracket for wall mounting of positioner
Order no. 1445 000 Z MP

Please order mounting bracket and travel sensor separately, see following pages.

Electrical connection - Standard version

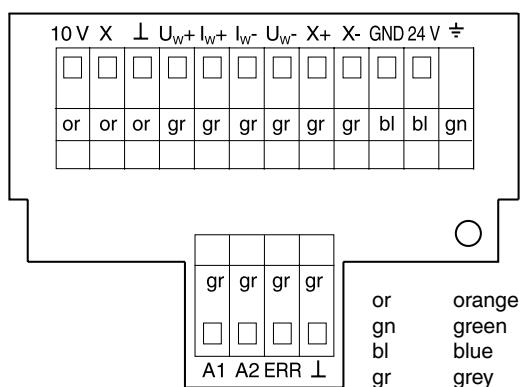

Legend

10 V	green	Connection of external travel sensor
X	brown	
⊥	white	
I _{w+}		Set value input 0 / 4-20 mA
I _{w-}		
U _{w+}		Set value input 0 - 10 V
U _{w-}		
X+		Actual value output 0 - 10 V 4-20 mA (optional) - internal supply
X-		
GND		Supply voltage 24 V DC
24V		
⏏		Potential earth
A1		Alarm 1
A2		Alarm 2
ERR		Error message output
⊥		GND out

Electrical connection- M12 connection (optional)

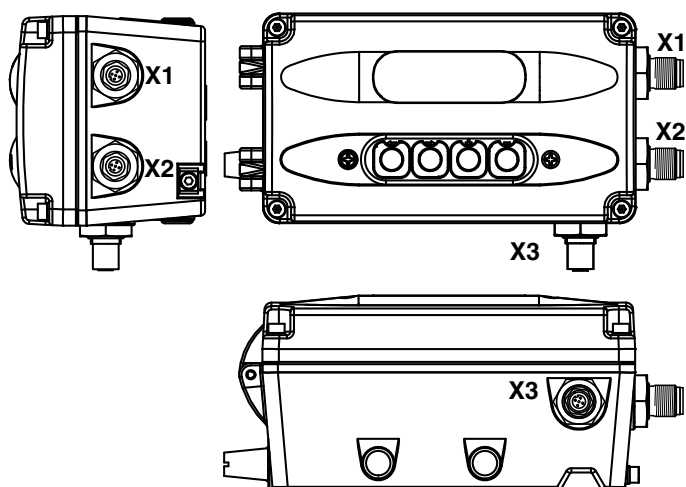

Connection	Pin	Ctr	Signal name
X1 A-coded M12 plug	1	I	U _v , 24 V DC supply voltage
	2	O	U _o , error message output, 24 V DC
	3	I	U _v , GND supply voltage
	4	O	U _o , alarm output 1, 24 V DC
	5	O	U _o , alarm output 2, 24 V DC

Connection	Pin	Ctr	Signal name
X2 A-coded M12 plug	1	I	I _{w+} , set value input 0 / 4-20 mA*
	2	I	I _{w-} , set value input 0 / 4-20 mA*
	3	O	X+, actual value output 0 - 10 V / 4-20 mA
	4	O	X-, actual value output 0 - 10 V / 4-20 mA
	5	X	n.c.

Connection	Pin	Ctr	Signal name
X3 A-coded M12 socket	1	O	U _v , actual value supply 10 V DC
	2	I	U _{sig} , actual value input 0 - 10 V DC
	3	O	U _v , actual value supply GND
	4	X	n.c.
	5	X	n.c.

* For set value input U_w = 0 - 10 V on-site rewiring is required

Pneumatic connection

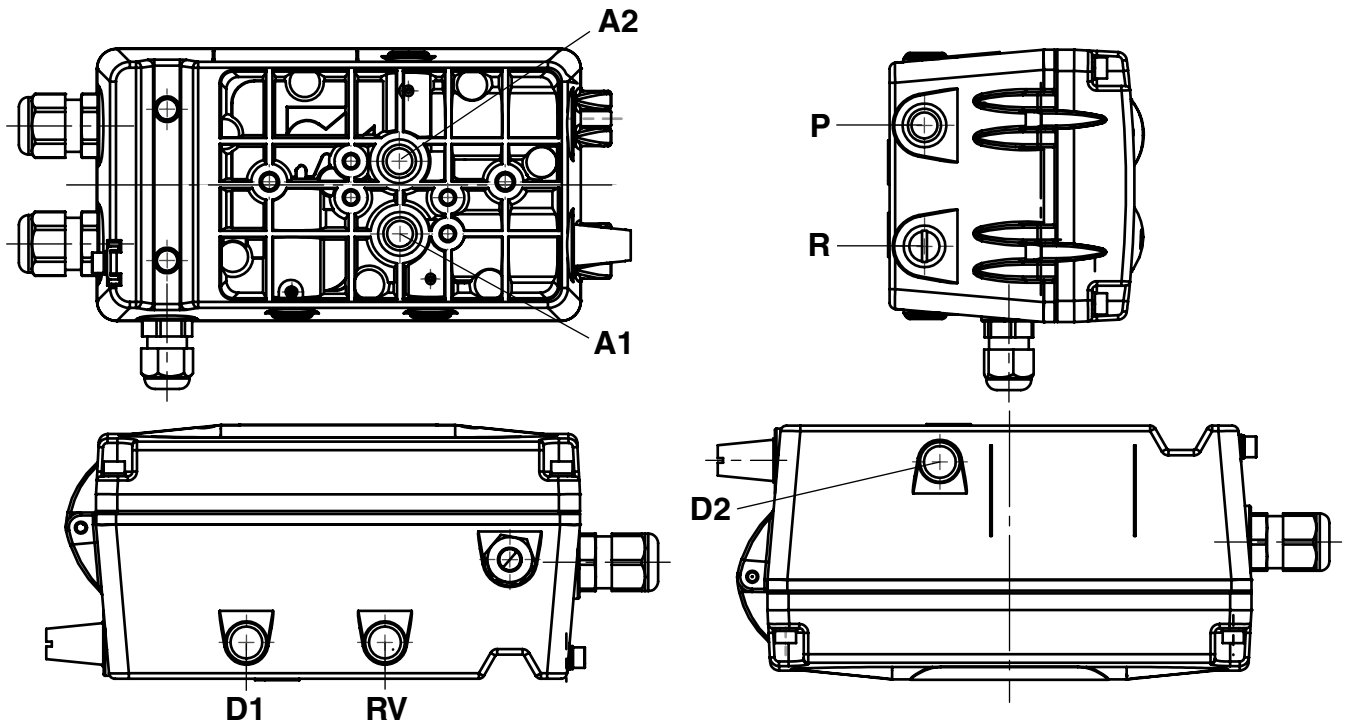

Connector	DIN ISO 1219-1	Description
P	1	Air supply connector G1/4
R	3	Venting connection G1/4 with silencer
D1	V1	Exhaust air throttle for A1
D2	V2	Exhaust air throttle for A2*
RV	V3	Non-return valve
A1	2	Working connection for process valve
A2	4	Working connection for process valve*

* only double acting type (code 3)

Fail safe function

Error	Outlet A1	Outlet A2
Electrical power supply failure	Single acting: vented Double acting: vented	Single acting: non existent Double acting: pressurized
Pneumatic supply failure	Single acting: vented Double acting: undefined, dependent on the operating conditions of the actuator	Single acting: non existent Double acting: undefined, dependent on the operating conditions of the actuator

This fail safe function is not a substitute for specific plant safety requirements

Accessories



Spare filter strainers
Order number 1435 SFI



External throttle for control function 2
(spring opening)
Order no. 1435DR6Z

Mounting examples

Remote mounting



GEMÜ 650 diaphragm valve, metal
with GEMÜ 1435 ePos®



GEMÜ 550 globe valve, metal
with GEMÜ 1435 ePos®

Direct mounting



GEMÜ 690 diaphragm valve, plastic
with GEMÜ 1435 ePos®



GEMÜ 512 globe valve, metal
with GEMÜ 1435 ePos®

All rights including copyright and industrial property rights are expressly reserved.

Should there be any doubts or misunderstandings, the German version of this data sheet is the authoritative document!

Subject to alteration · 11/2015 · 88101193

GEMÜ® VALVES, MEASUREMENT
AND CONTROL SYSTEMS

